

Reduced Bore Ball Valves

Three-piece design

A44 - Standard series

This 3-piece Ball Valve is the most easily on-line maintainable in its class. By removing three body connector bolts and loosening the fourth, the body can be swung away using the fourth bolt as the fulcrum, to carry out any installation or maintenance operation on the valve, thus reducing downtime. This valve can be offered in a wide variety of body and seat combinations.

AF44 - Fire-safe series

This 3-piece fire-safe design Ball Valve features a secondary metal seat which renders the valve fire-safe. When the seat is totally sublimated in a fire, the ball moves and rests against the lip, forming a metal-to-metal seat, thus ensuring leak-tightness.

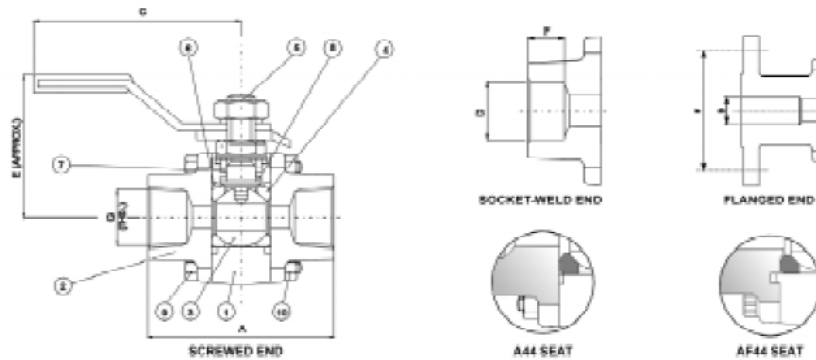

Dimensional Details

Screwed/Socket-weld end (in mm, unless specified)

Valve Size	A	C	D	E	F	G	Approx. Weight (kg)
8	65	122	14.6 / 14.2	45	9.7	1/4"	0.6
10	65	122	18.0 / 17.6	45	9.7	3/8"	0.6
15	67	122	22.2 / 21.8	45	9.7	1/2"	0.6
20	73	122	27.6 / 27.1	48	12.7	3/4"	0.8
25	95	149	34.3 / 33.8	59	12.7	1"	1.6
32	107	149	43.1 / 42.7	65	12.7	1 1/4"	2.5
40	116	181	49.2 / 48.7	75	12.7	1 1/2"	3.3
50	128	181	61.7 / 61.1	80	15.9	2"	4.1

